

RIGHT-HAND SQUEEZE LOCKBOX CLEANING/PARTS REPLACEMENT

REQUIRED TOOLS

- 2x 9/16" wrench
- 1 x 3/4" wrench
- 1 x 3/4" socket

INSTRUCTIONS

1. Loosen the locknut on the rear bolt of the fandangle adjustment bracket tube, turn the bolt out till there is no threads showing on the front side of the fandangle adjustment yoke and rotate.

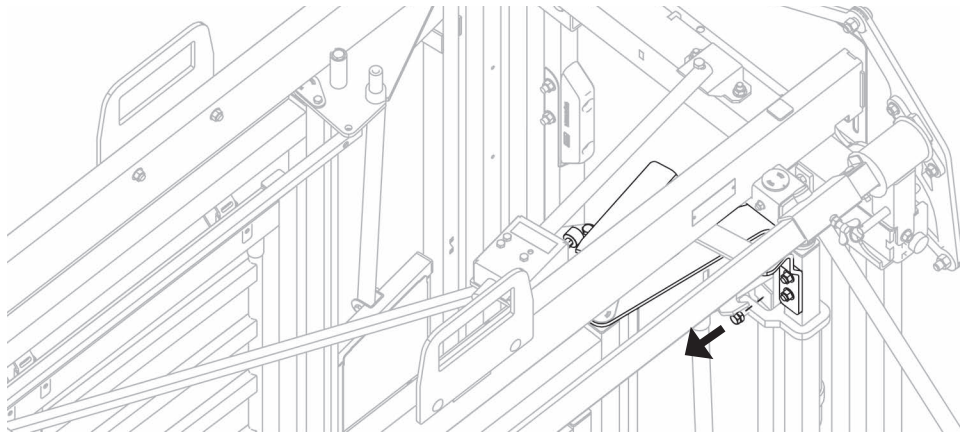

2. Open the Q-Catch Head Gate fully to step into the chute.

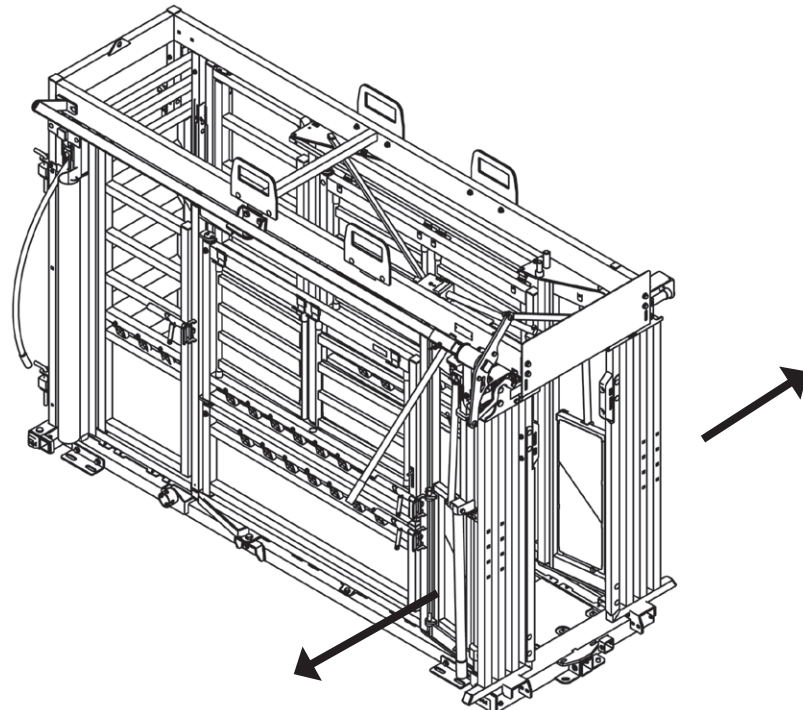

3. Remove bolts on the front bracket that connects to the top of the Head Gate track.
 - a. Remove "A" bolt.
 - b. Pull lock release pin toward the rear of the lock box.
 - c. Slide the long lock shaft toward the rear of the lock box past the "B" bolt.
 - d. Remove "B" bolt

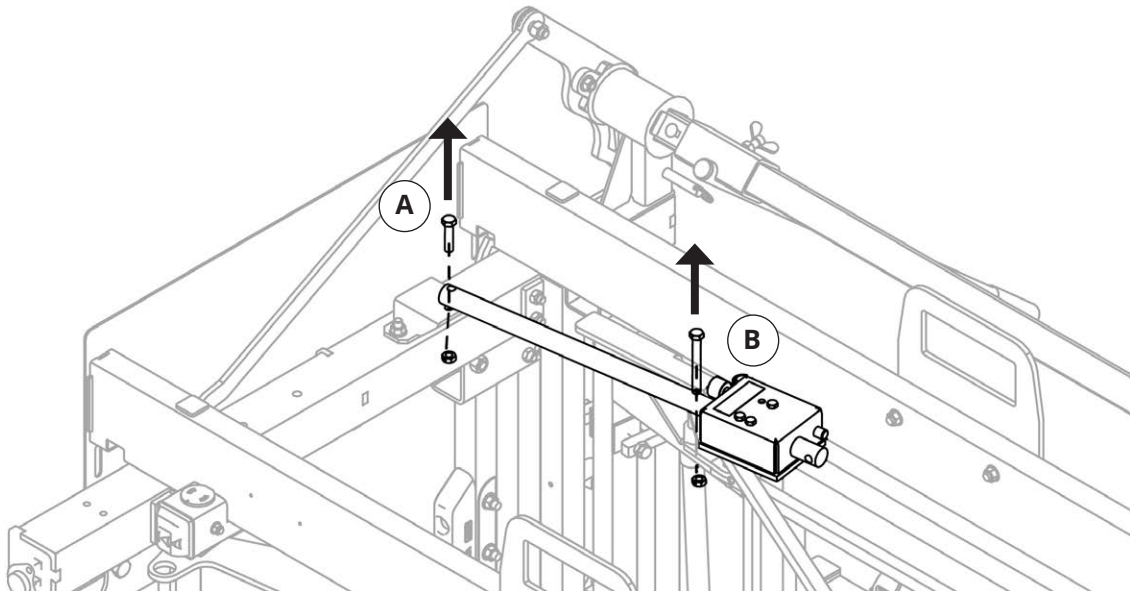

4. Lift the lock box assembly out of the chute carefully and place on your working surface.
5. Loosen the three bolts on the outside of the box while holding the nuts on the back of the lock plate.

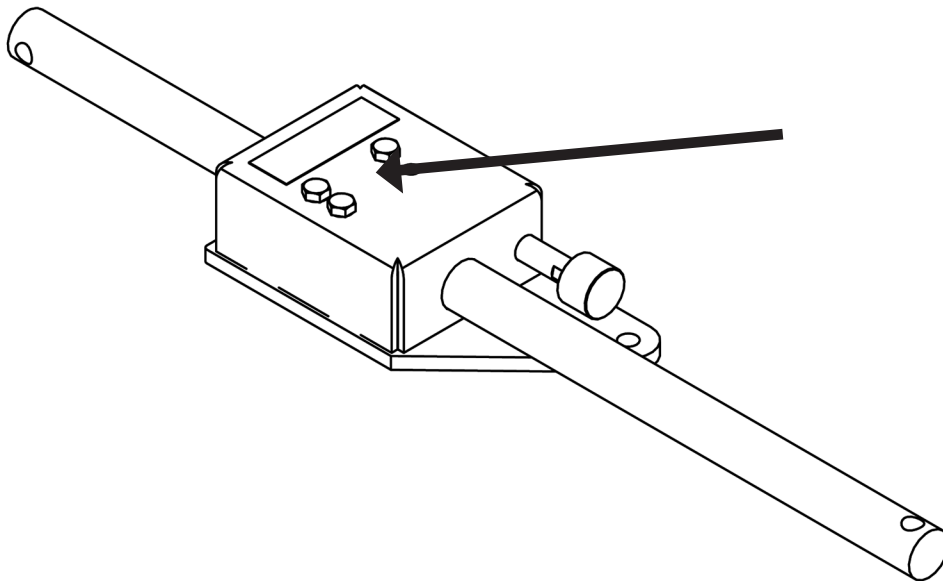

6. Turn the lockbox upside down and remove the three nuts.

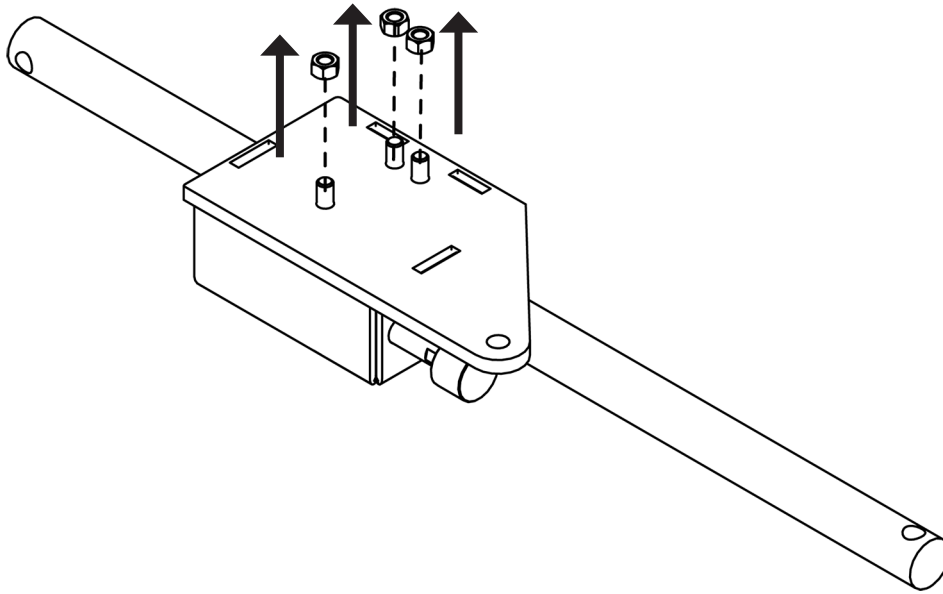

7. Remove the back plate to expose the locking mechanism.

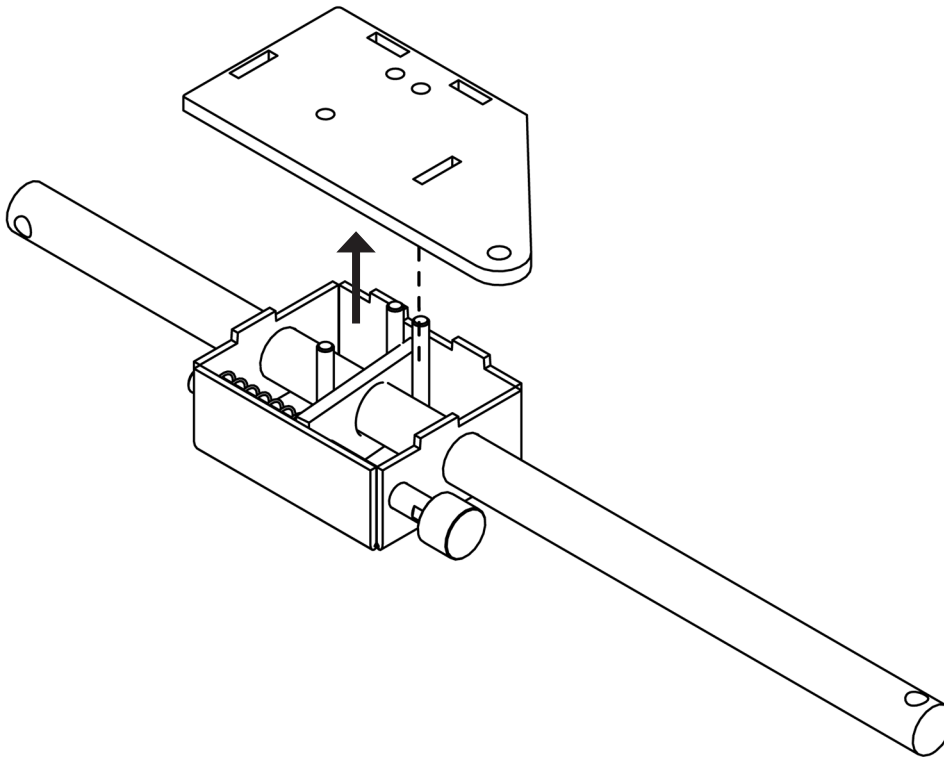

8. Push the lock pin, pushing the lock plate towards the two bolts, and remove the long lock shaft.

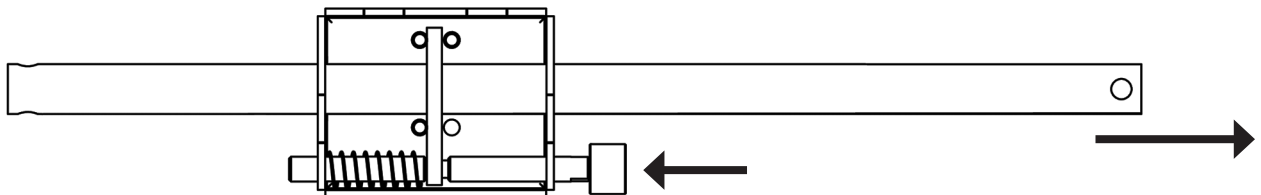

9. Lift the lockbox off the working remove the single bolt in front of the lock plate.

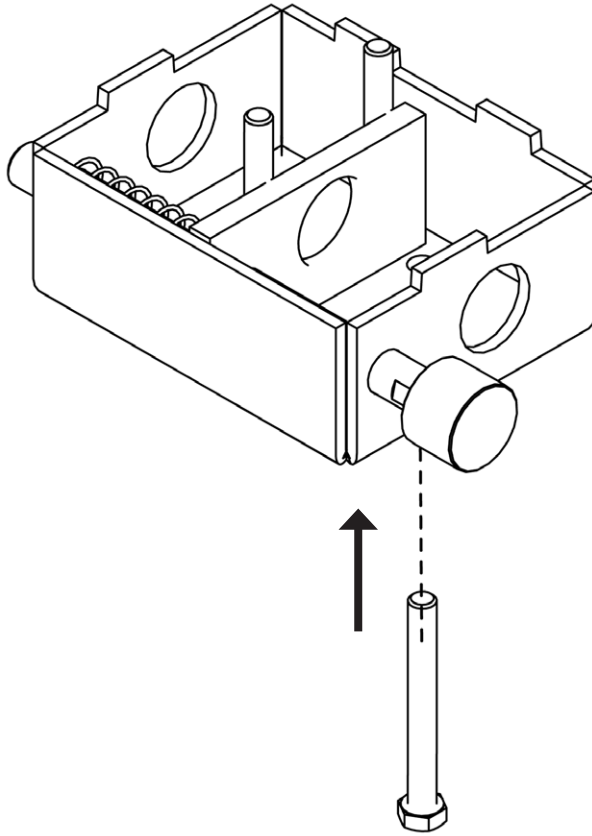

10. Slowly release pressure on the lock plate and remove the lock plate, spring, and small shaft from the mechanism.

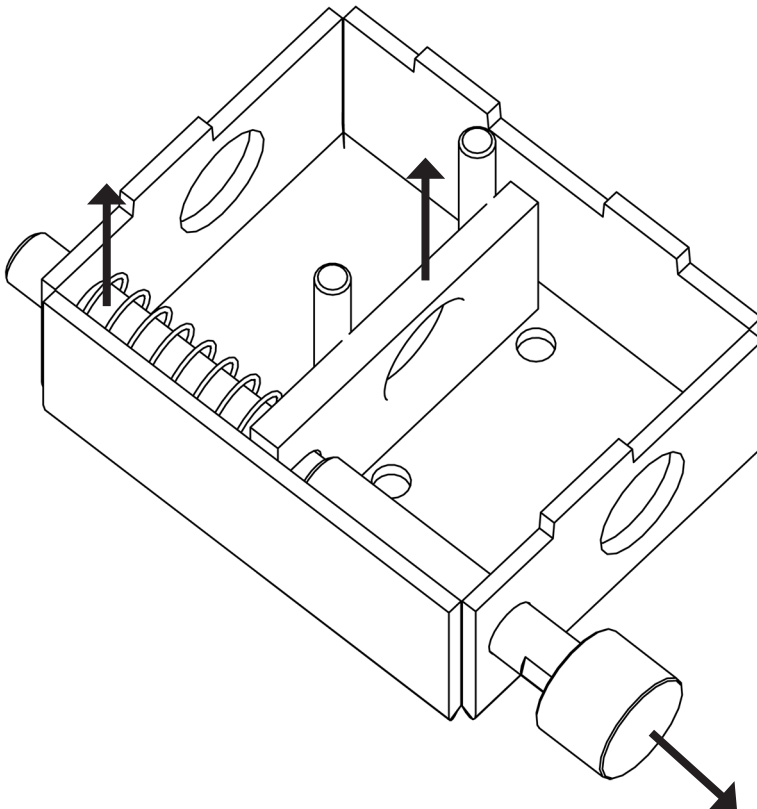

11. Clean the entire lockbox, including the back plate, spring, and shaft.

12. Reassemble lockbox in reverse order.

IMPORTANT NOTES

- The lock plate can only be installed in one direction. The edge of the lock plate must be slightly below the edge of the lockbox cover with the long shaft installed. If the lock plate is reversed, it will be above the edge of the lockbox.
- When lockbox is completely reassembled, tighten the three bolts and nuts to the housing until they are just slightly tighter than being able to turn them with your fingers (but you can still turn them with your wrench). If these are too tight, the housing will bind the lock plate on the backplate.

FURTHER ASSISTANCE

For further information or technical help call Arrowquip client care at 1-877-275-6075 or email cs@arrowquip.com.

