

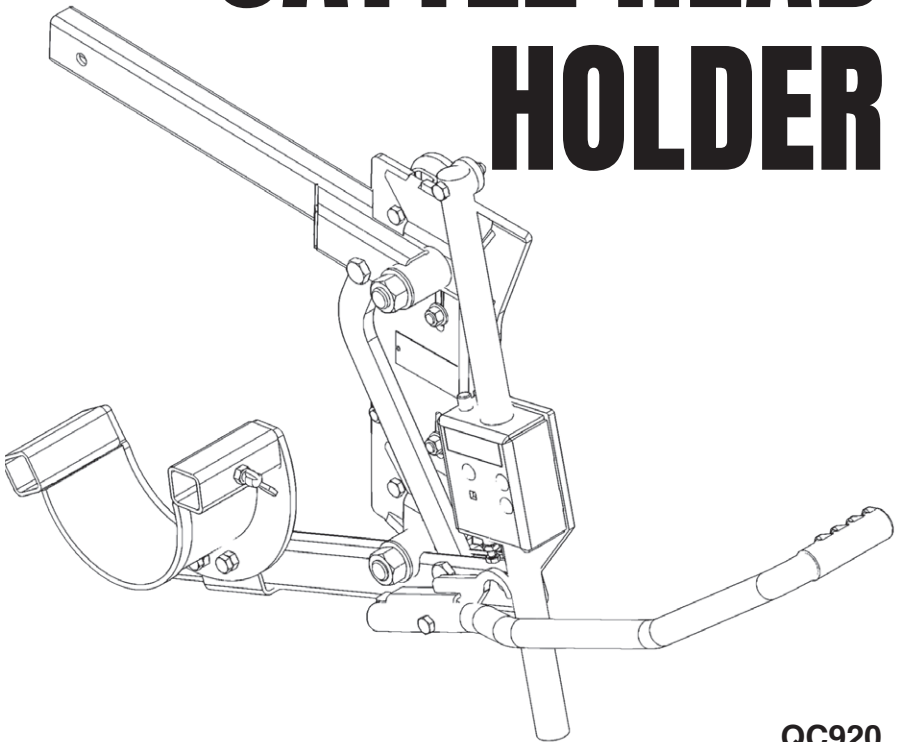

**ARROWQUIP**

## PRODUCT MANUAL

# Q-CATCH<sup>®</sup> CATTLE HEAD HOLDER



**QC920**

JUNE 2021

1-877-275-6075 | [cs@arrowquip.com](mailto:cs@arrowquip.com)  
[arrowquip.com](http://arrowquip.com)



# CONTENTS

---

Safety Precautions	1
Installing the Head Holder	1
Recommended Maintenance	3
Troubleshooting Guide	3
Warranty	4

**PLEASE FOLLOW ALL SAFETY INSTRUCTIONS PROVIDED IN THIS MANUAL BEFORE OPERATION. ARROWQUIP DOES NOT ACCEPT RESPONSIBILITY FOR ANY ACCIDENTS OR INJURY WHEN THIS SAFETY MANUAL HAS NOT BEEN READ IN FULL AND KEPT WITH THE PRODUCT AT ALL TIMES. OPERATORS OF THIS PRODUCT TAKE AND ACCEPT RESPONSIBILITY FOR ANY HARM OR INJURY TO THE ANIMAL OR OPERATOR WHEN IT PERTAINS TO HOW THE EQUIPMENT IS USED AND MAINTAINED.**

Please keep this manual for frequent reference and to pass on to new users or owners.

## **SAFETY PRECAUTIONS**

---

**PLEASE FOLLOW ALL SAFETY PRECAUTIONS OUTLINED HEREIN. ANY HARM TO THE ANIMAL OR INJURY TO THE OPERATOR WHICH OCCURS DUE TO HOW THE PRODUCT IS OPERATED, OR RESULTING FROM A LACK OF SAFETY PRECAUTIONS ARE THE SOLE RESPONSIBILITY OF THE OPERATOR.**

All farm machinery and equipment are potentially dangerous. Careless use of any Arrowquip livestock equipment may cause injury or damage to persons, cattle, or property. Arrowquip has taken precautions in the design and manufacturing of this product to ensure that it is safe and user-friendly. Therefore, the user must assume all responsibility and risk associated with the possession and use of the cattle equipment.



**WARNING: READ BELOW BEFORE OPERATION.**

Ensure the operator understands the contents of this manual before using the cattle equipment.

1. **DO NOT** wear loose-fitted clothing.
2. Ensure that the head holder remains open until required to hold the animal's head.
3. **DO NOT** make any modifications to Arrowquip equipment. Non-factory modifications to the equipment can reduce the safety for the operator & livestock, and void warranty.

## **INSTALLING THE HEAD HOLDER**

---

### **Requirements:**

- 2 people
- 3/4" wrench

**Installation:**

- 1** a. Insert 4x1/2-13x3" carriage bolts through the head gate door from inside the chute.  
b. Align the head holder to the slots in the head gate according to your desired height.

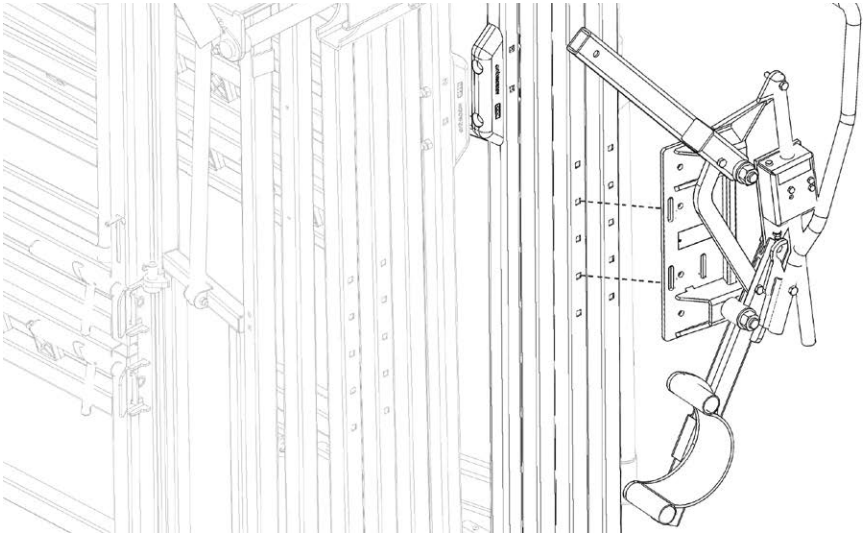

- 2** Secure the head holder with 4 bolts.

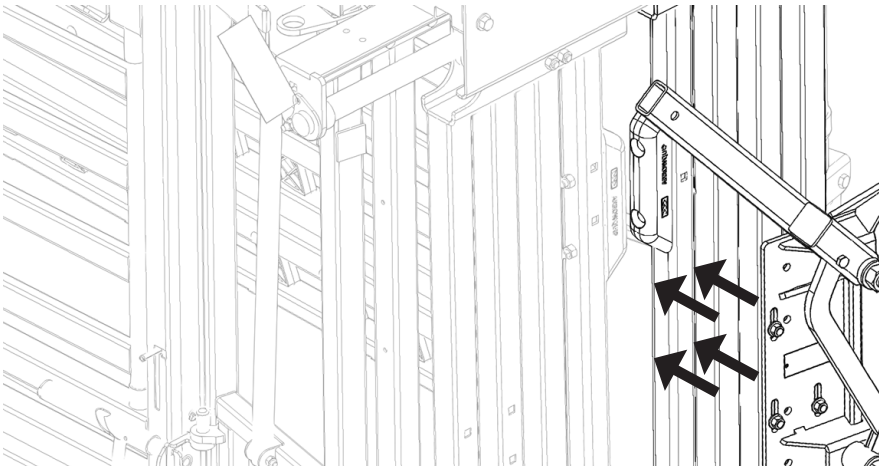

**Safety Precautions:**

1. Ensure that the head holder remains open until required to hold the animal's head.
2. If not in use, use detent pin to hold the head holder in place.

## RECOMMENDED MAINTENANCE

---

1. Add grease through the grease nipples **as needed**.
2. Every 6 months:
  - a. Check bolts to ensure they are tightened properly.
  - b. Spray brake cleaner on a rag and wipe the lockbox shaft while opening and closing the head holder.

## TROUBLESHOOTING GUIDE

---

If you have a problem with your Head Holder, please consider the following tips or call us at 1-877-275-6075.

### **PROBLEM: HEAD HOLDER IS TOO TIGHT**

#### **SOLUTION:**

1. Spray WD-40 Dry Lube on a rag. Wipe the lockbox shaft while opening and closing the head holder to work the lubricant in.
2. Spray WD-40 Dry Lube directly on the pivot points.
3. Add grease through the grease nipples.

### **PROBLEM: HEAD HOLDER IS SLIPPING**

#### **SOLUTION:**



**USE WD-40 DRY LUBE ONLY. USE OF OTHER LUBRICANTS, INCLUDING OTHER WD-40 MAY CAUSE MALFUNCTION OF THE HEAD HOLDER.**

1. Clean the Lock Box shaft and inside the Lock Box with brake cleaner to remove build-up.
  - a. Thoroughly clean all parts of the lock, including wiping down the shaft with brake cleaner.
2. Open and close the Head Holder a few times, then confirm that all build up is removed. Repeat Step 1 if necessary.
3. Using the Head Holder operation handle, close the Head Holder half-way.
4. Pull on the Head Holder to test the security of the lock.
  - a. If the lock continues to slip, contact Arrowquip Client Care to determine if replacement parts are needed.
  - b. If the locks are secure, move on to Step 5.

5. If the Head Holder is sticking or binding on the shaft, apply WD-40 Dry Lube sparingly with a cloth to the Head Holder shaft.



**WARNING! DO NOT SPRAY WD-40 DRY LUBE DIRECTLY ON THE SHAFT OR INSIDE THE LOCK BOX AS THIS MAY CAUSE MALFUNCTION.**

6. Open and close the Head Holder a few times to work the lubricant in.

## **WARRANTY**

---

Your product must be registered to claim warranty, and to ensure that Arrowquip has the required information to contact you in the event of a product or part recall. Any owner who fails to register their product warranty with Arrowquip through their Authorized Arrowquip Dealer voluntarily voids their warranty. Arrowquip will repair or replace products or parts of a product that prove defective due to manufacturer defect during the Warranty Period, at their sole discretion. This excludes defects resulting from normal wear and tear or product misuse. Warranty does not cover corrosion. NOTE: Any modification, in any fashion, to any Arrowquip equipment immediately voids the product warranty. This includes the parts contained therein.

Eg. If a modification is made to the squeeze mechanism in a squeeze chute, and the sternum bar is bent afterwards, warranty for the damaged part, the sternum bar, contained in the modified equipment, the squeeze chute, is void. In addition, any remaining warranty for the squeeze chute and other parts contained therein, including, but not limited to, the head gate, locking system, Q-Catch system, and rollers, is null and void.

**REGISTER FOR WARRANTY NOW:**

**Online:** [arrowquip.com/product-registration](http://arrowquip.com/product-registration)

**Phone:** 1-877-275-6075 | **Email:** [cs@arrowquip.com](mailto:cs@arrowquip.com)



**ARROWQUIP**

If you have any questions regarding your product or require assistance, please contact Arrowquip's Client Care Team at 1-877-275-6075 or by email at [cs@arrowquip.com](mailto:cs@arrowquip.com).